

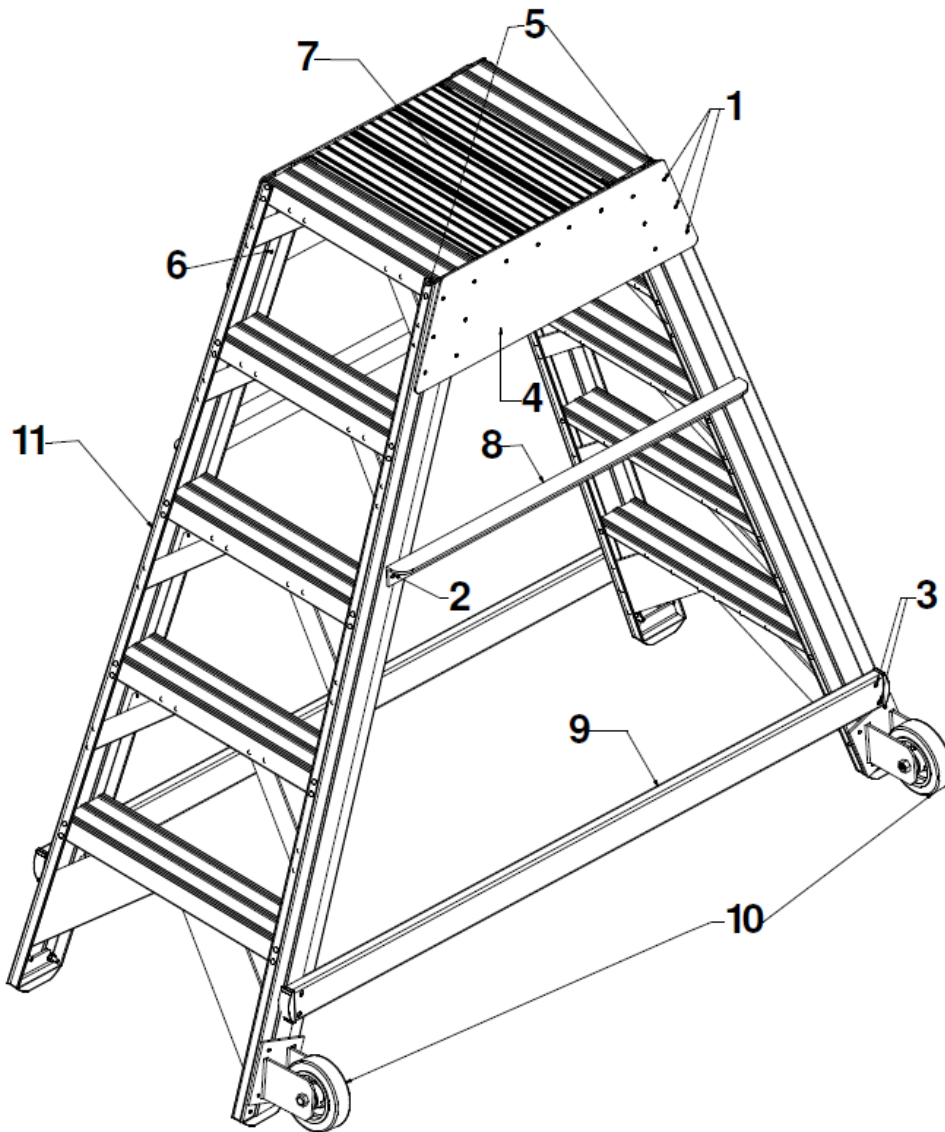

Aircraft Maintenance Ladder Assembly Instructions



PARTS LIST



ITEM NUMBER	QTY	DESCRIPTION
1	32	1/4" x 7/8" Hex Head Cap Screw, Hex Elastic Lock Nut & Flat Washer
2	4	1/4" x 7/8" Hex Head Cap Screw, Hex Elastic Lock Nut & Flat Washer
3	8	3 8 5/16" x 1 3/4" Hex Head Cap Screw, Hex Elastic Lock Nut & Flat Washer
4	2	Head Side Plate
5	4	Head Side Plate Shim
6	4	Back Up Plates
7	1	Head (11 7/8" x 16") or (11 7/8" x 20")
8	2	*Mid Cross Arm (1 1/2" x 1 1/2" Angle)
9	2	Bottom Cross Arm (2 1/2" Aluminum Side Rail w/ Cast Aluminum End Plugs)
10	2	Wheel Assembly (Will come assembled on ladder unless being shipped UPS)
11	2	Stepladder Front



PLEASE READ INSTRUCTIONS BEFORE ASSEMBLING LADDER

STEP #1 Remove banding and loose parts from frame or ladder

STEP #2 Lie ladder fronts on floor with wheel assemblies facing up.

(If wheel assemblies are not included, ladder steps should be perpendicular to the floor surface.)

STEP #3 Attach one Head Side Plate (Item #4), two Head Side Plate Shims (Item #5) and one Back Up Plate (Item #6) using Twelve $1/4" \times 7/8"$ Hex Head Cap Screws, Hex Elastic Lock Nut, & Flat Washers.

NOTE: The Side Plate Shims are placed on the outside edge of the ladder fronts first. Then the Head Side Plate is placed on top of it. The back Up plate is placed on the middle rib on the inside of the Stepladder front.

STEP #4

Attach the Head using four $1/4" \times 7/8"$ Hex Head Cap Screws, Hex Elastic Lock Nuts, & Flat Washers.

STEP #5 Attach Mid Cross Arm using two $1/4" \times 7/8"$ Hex Head Cap Screws, Hex Elastic Lock Nut, & Flat Washers.

STEP #6 Attach Bottom Cross Arm using four $5/16" \times 1 3/4"$ Hex Head Cap Screws , Hex Elastic Lock Nuts & Flat Washers.

(The hardware will be attached to the part being used.)

Step #7 Tighten all bolts on entire side of ladder then turn ladder over and repeat from **STEP #3**.

NOTE: Parts will be numbered or letter coded, make sure that the corresponding number or letter on the ladder front matches of the part being used.

NOTE: DO NOT tighten bolts until Head Side Plate, Head Side Plate Shims, Back Up Plate, Mid Cross Arm, and Bottom Cross Arm are completely installed on one side.